



CONE CLIMBER Diamond

TAY- CC05-CCDIA-00

EN1176-1:2017

EN1176-11:2014





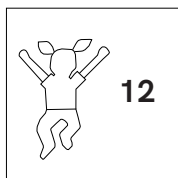



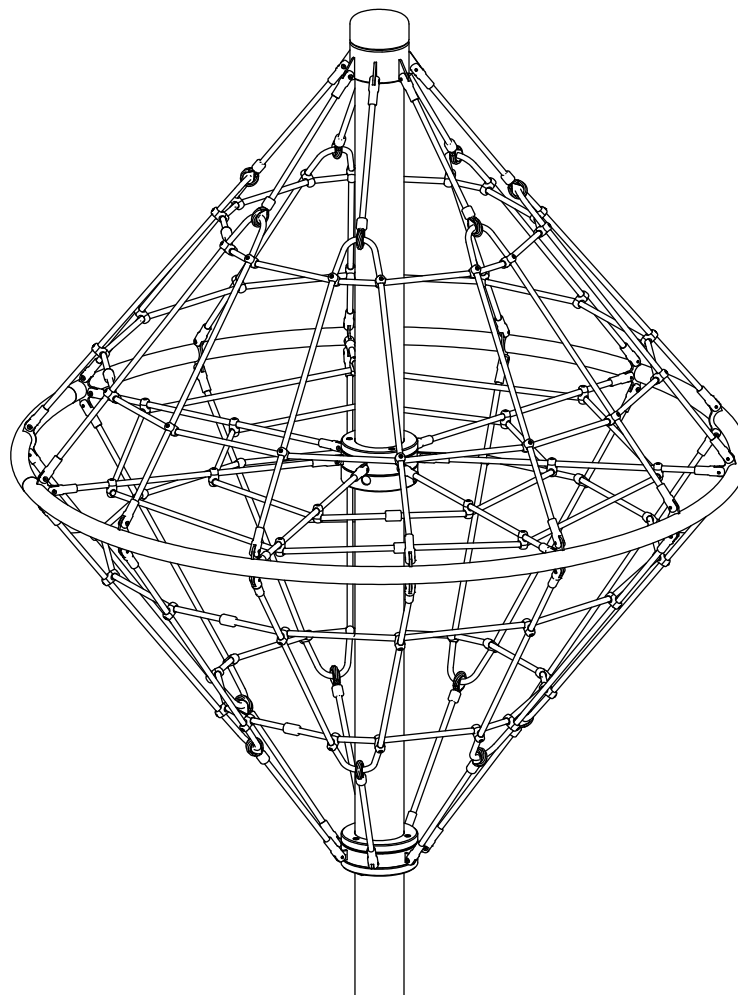









3+







Ø 8.1m

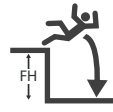

#			
2		SW82959	11kg
1		SW82693	6kg
1		SW82075	14kg
1		SW82016	9kg
1		TAY-51212	
1		SW82105	40kg
1		M8x100 A2 CSK SCS	
2		SW81995	1kg
2		SW82026	3kg
1		SW81996	1kg
1		M8 A2 NYLOC	
35		SW82232	
35		SW82233	

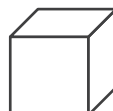
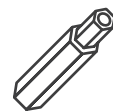
35		M6x25 A2
2		SW82090
4		T00844
1		SW82088

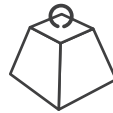
<p>S6</p>  <p>EN1176</p> <p>2320mm</p>	<p>S14</p>  <p>m²</p> <p>32.2</p>	<p>S13</p>  <p>m³</p> <p>0.72</p>
<p>S15</p>  <p>L x W x H (m)</p> <p>8.1 x 8.1 x 3.0</p>	<p>S23</p>  <p>T30H</p>	<p>S20</p>  <p>8 X 24</p>
<p>S12</p>  <p>kg</p> <p>101</p>		



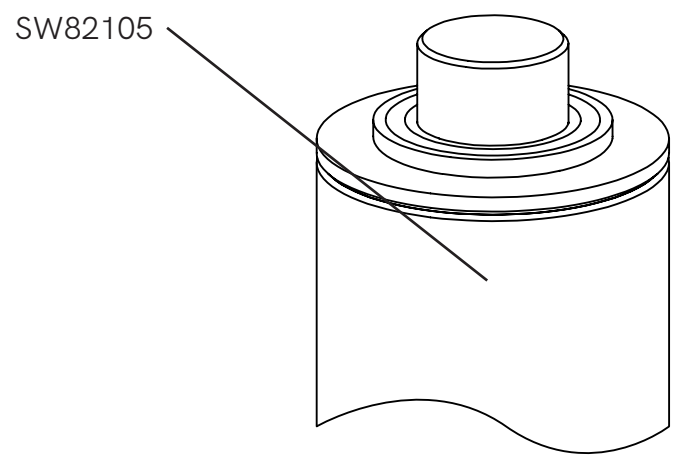
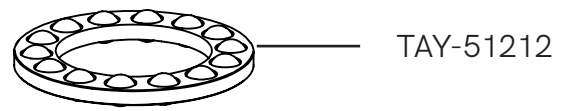
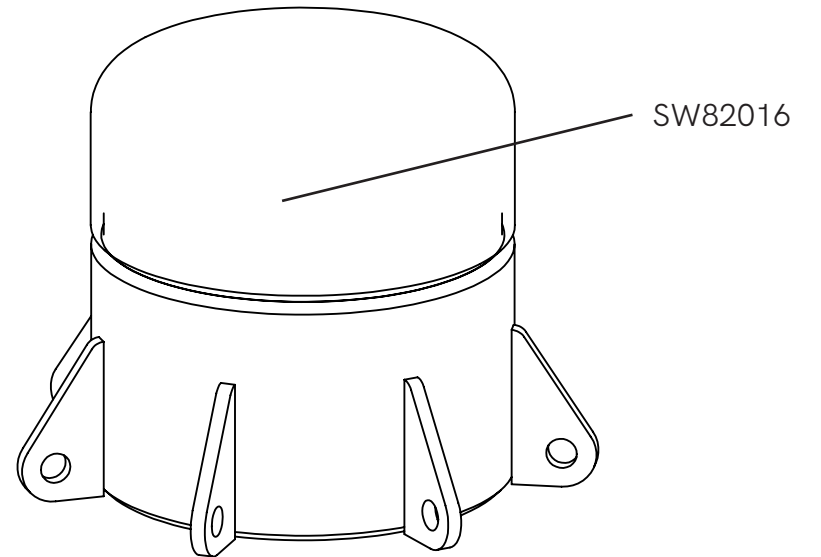
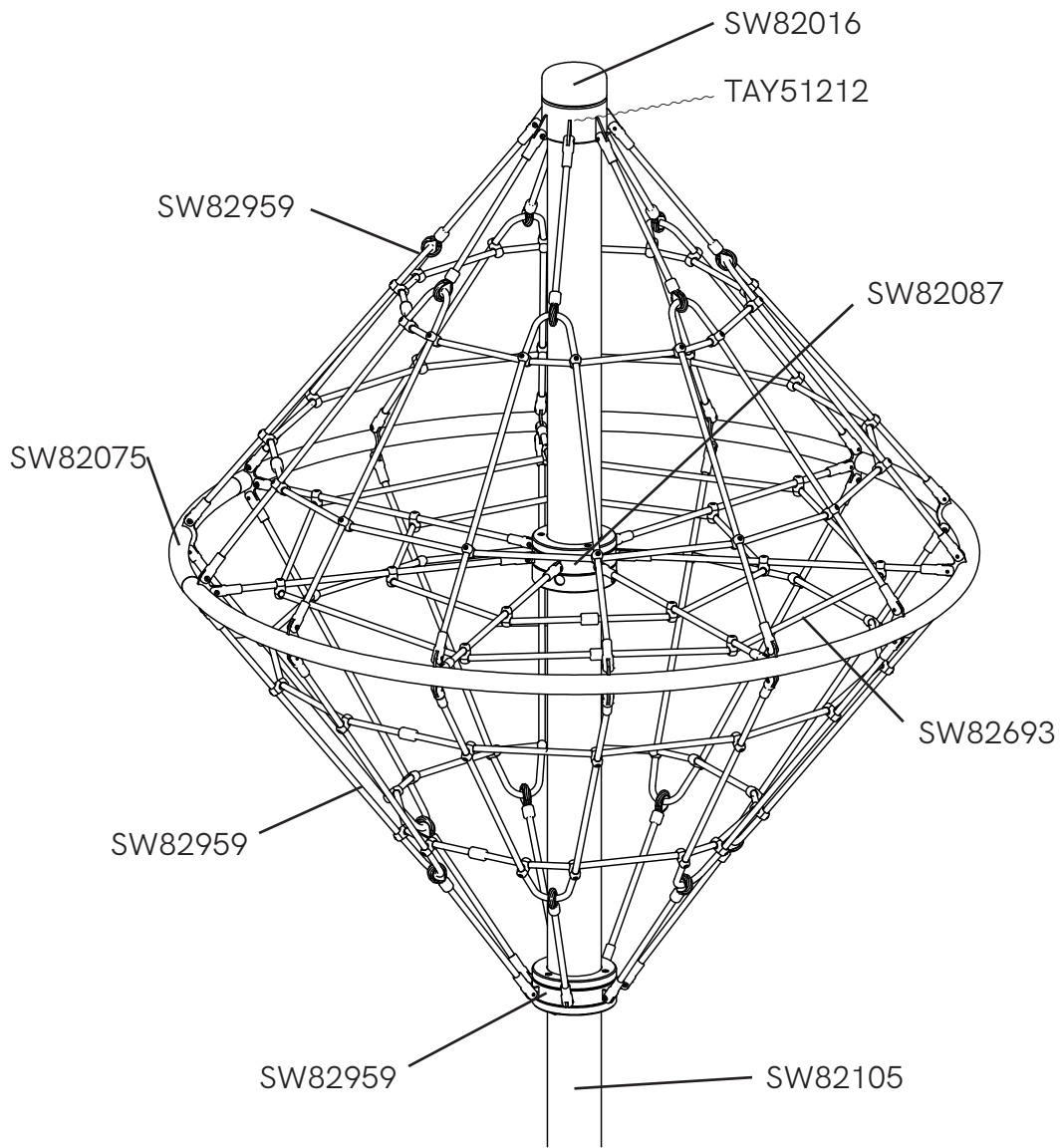

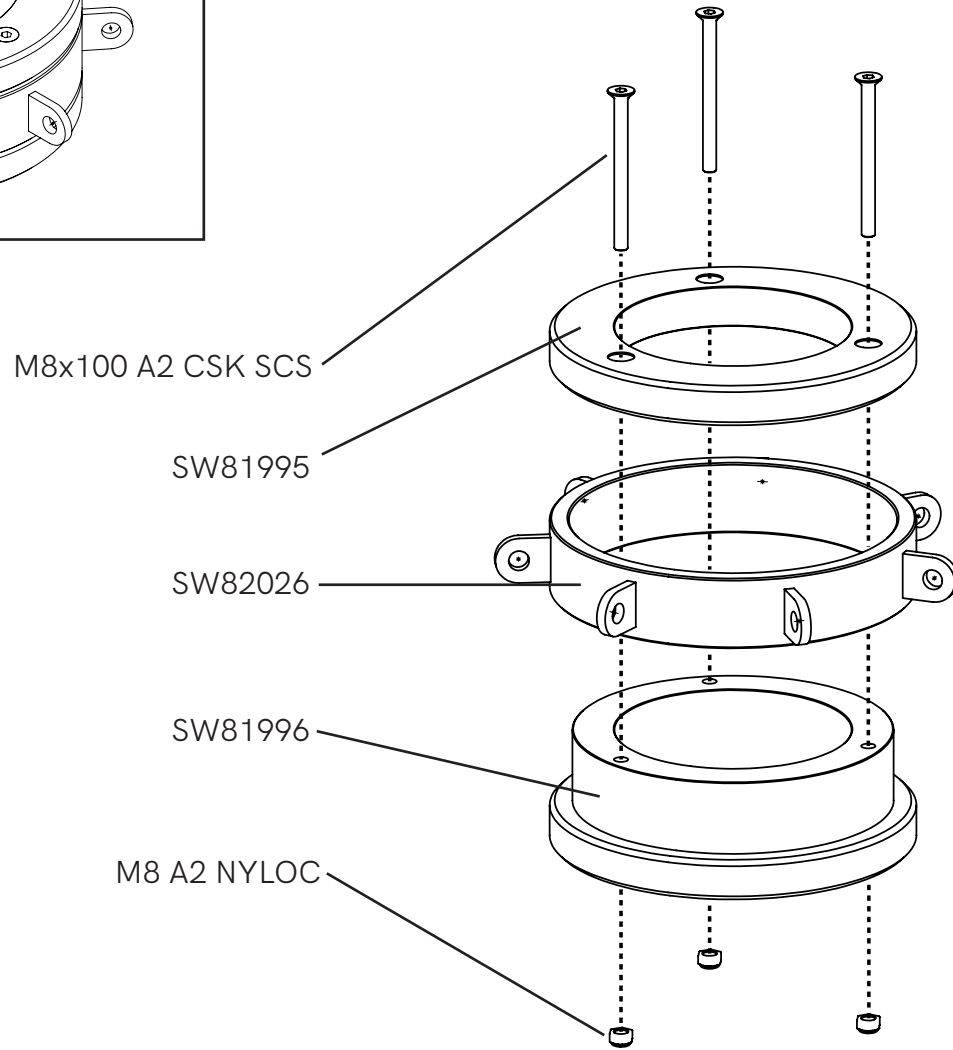
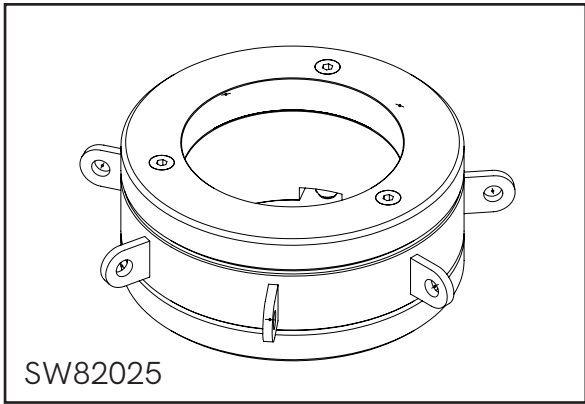

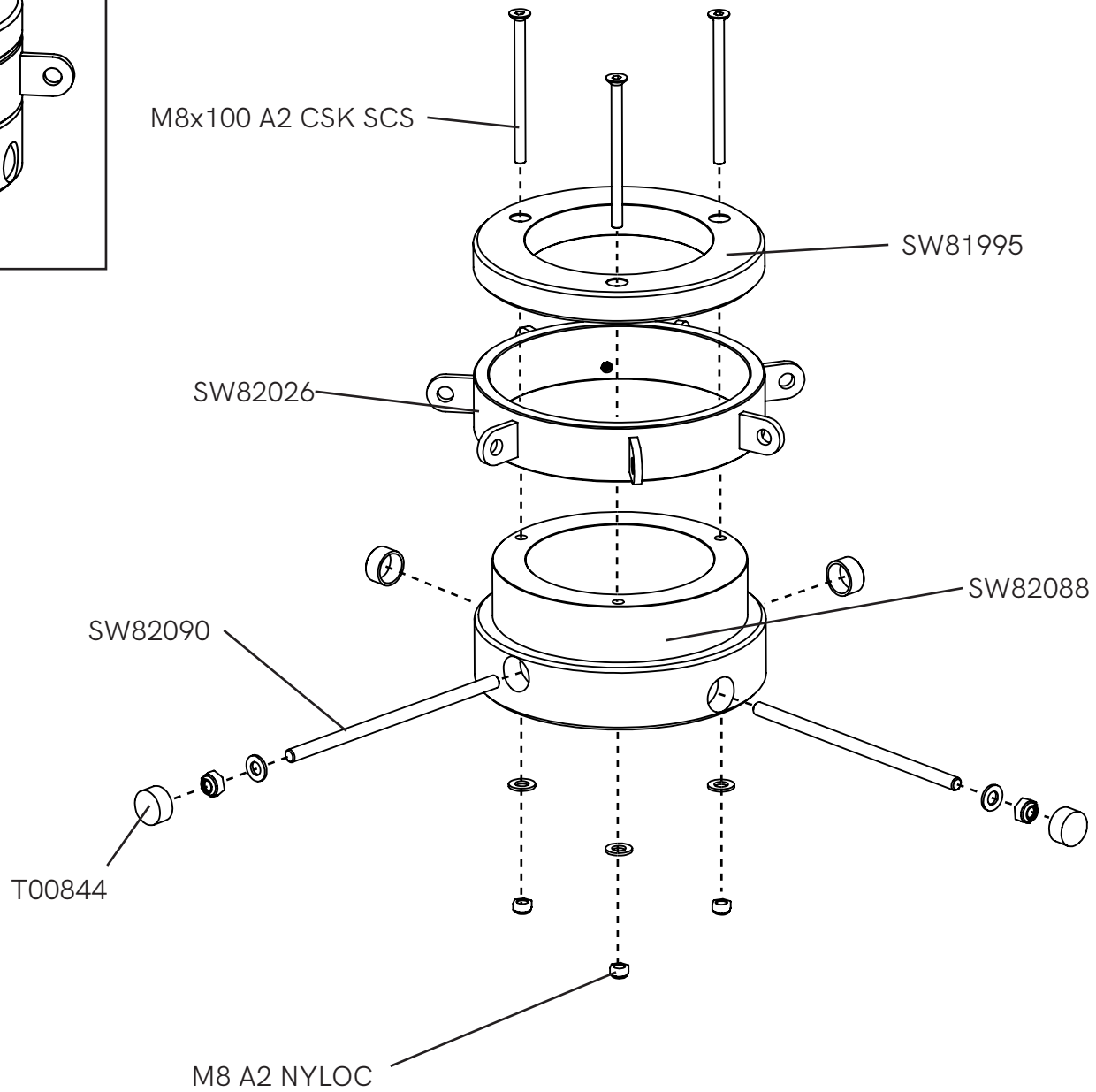
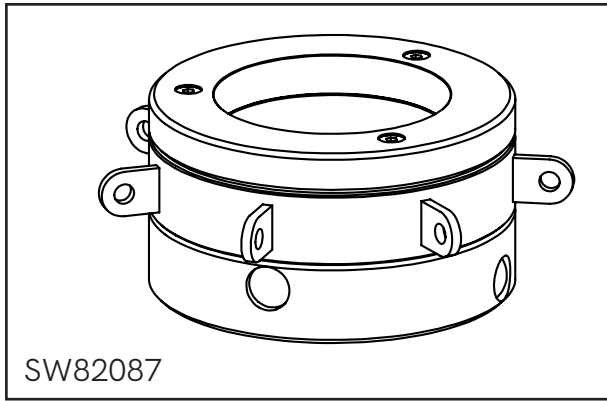

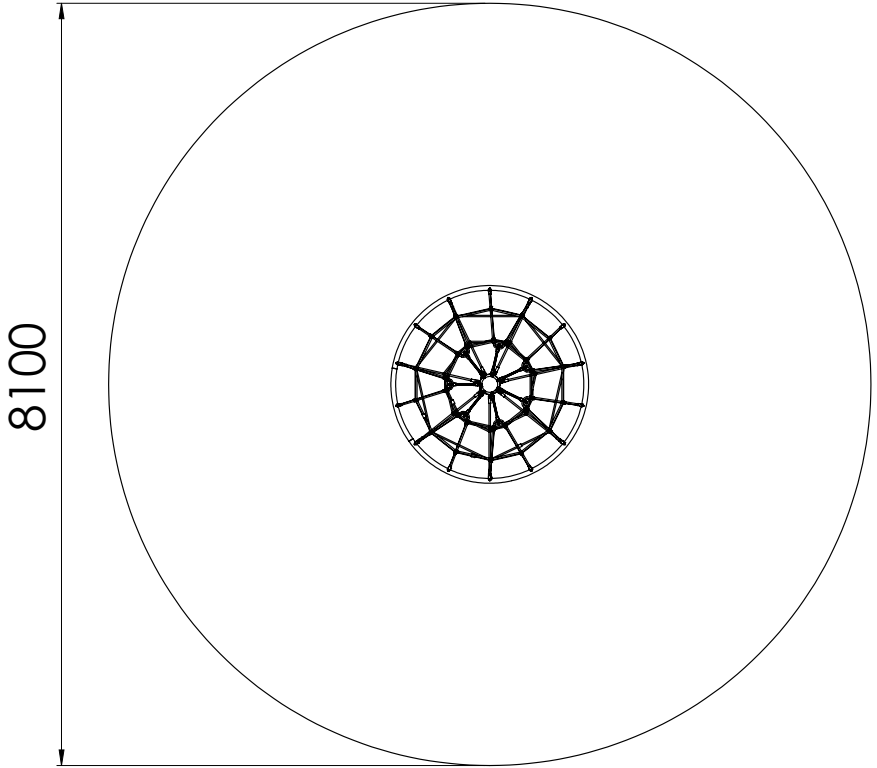
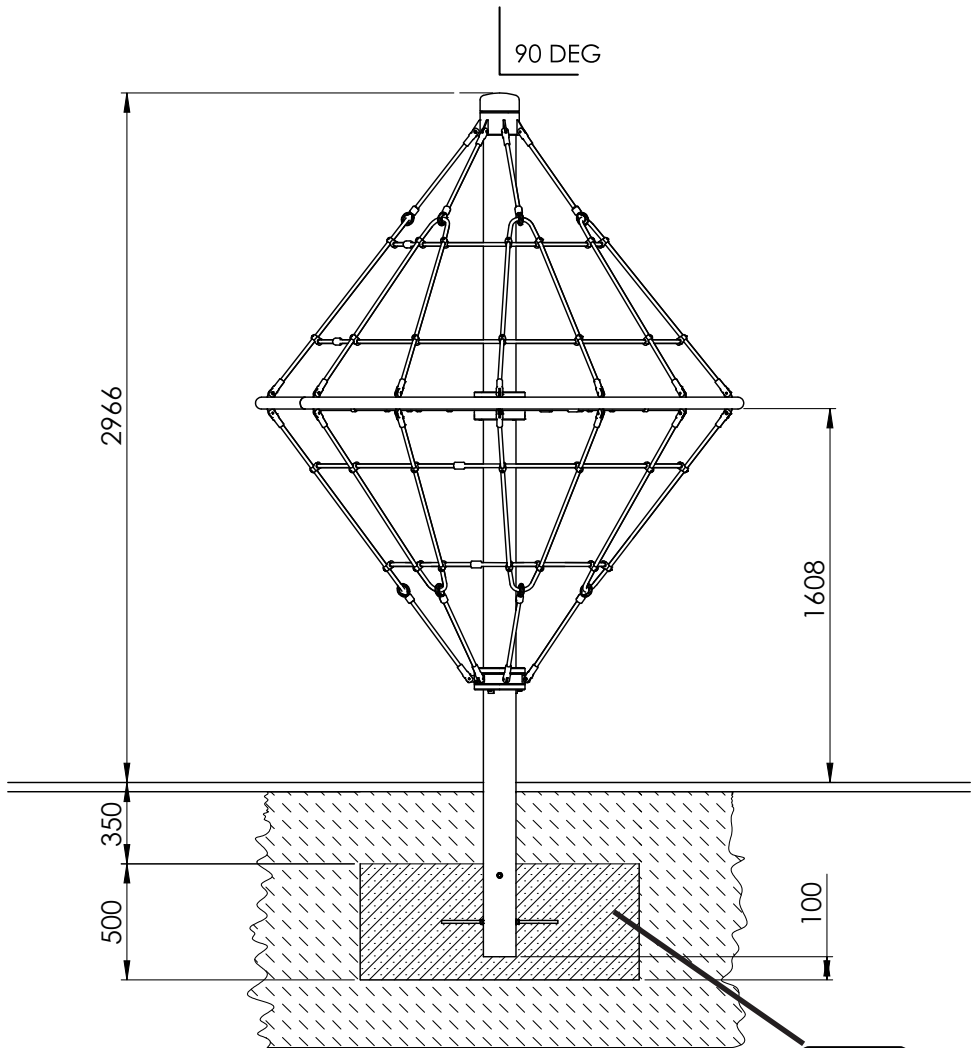
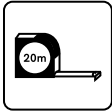

0.72m³
30N/mm²



TAY-CC05-CCDIA-00

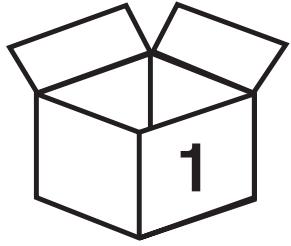

1

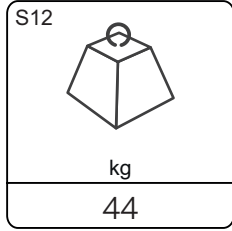

S12

kg

44

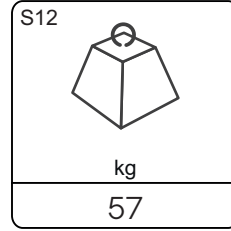

S12

kg

57

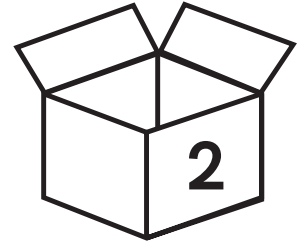

2

SW82105

SW81995

SW82088

SW81995

SW81996

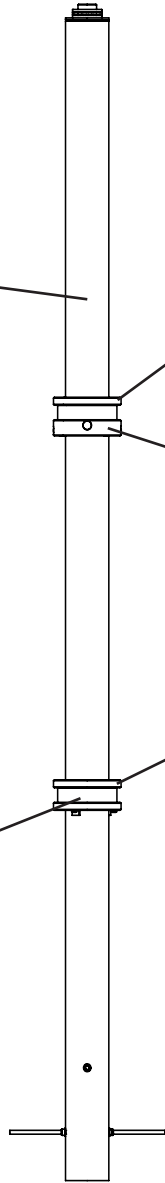

SW82016

TAY51212

SW82959

SW82075

SW82026

SW82693

SW82959

SW82026

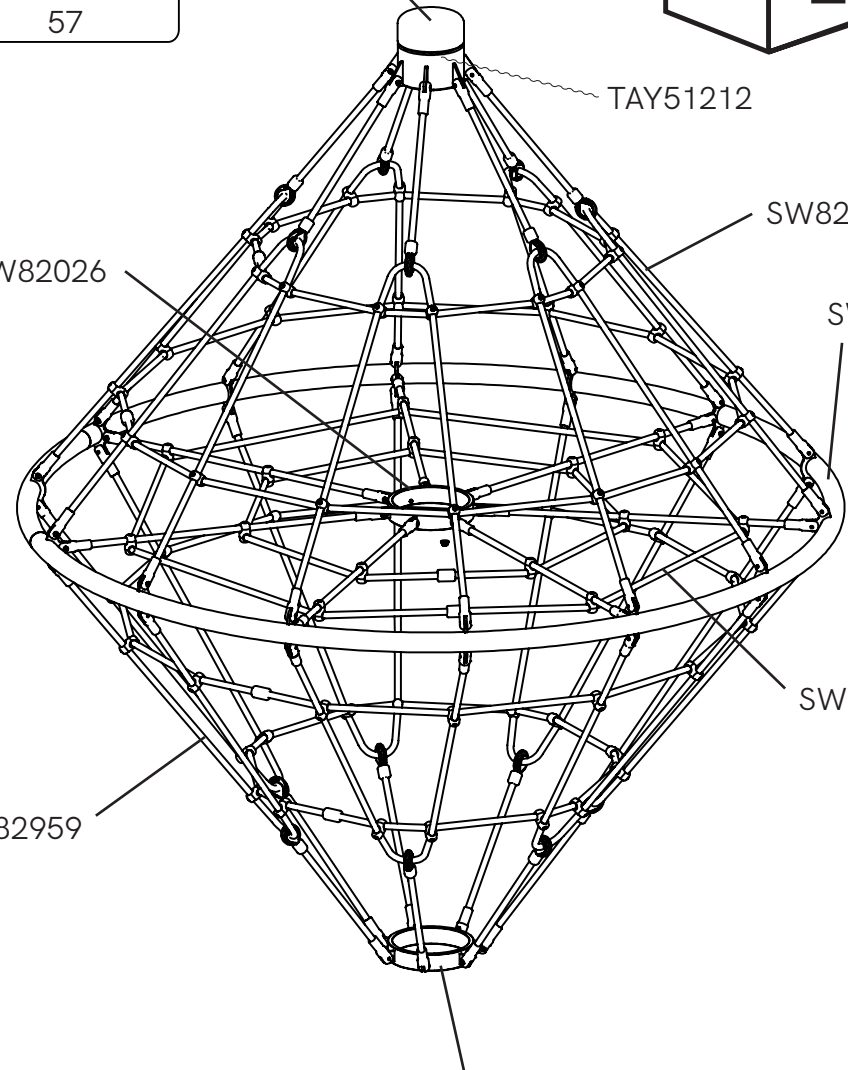

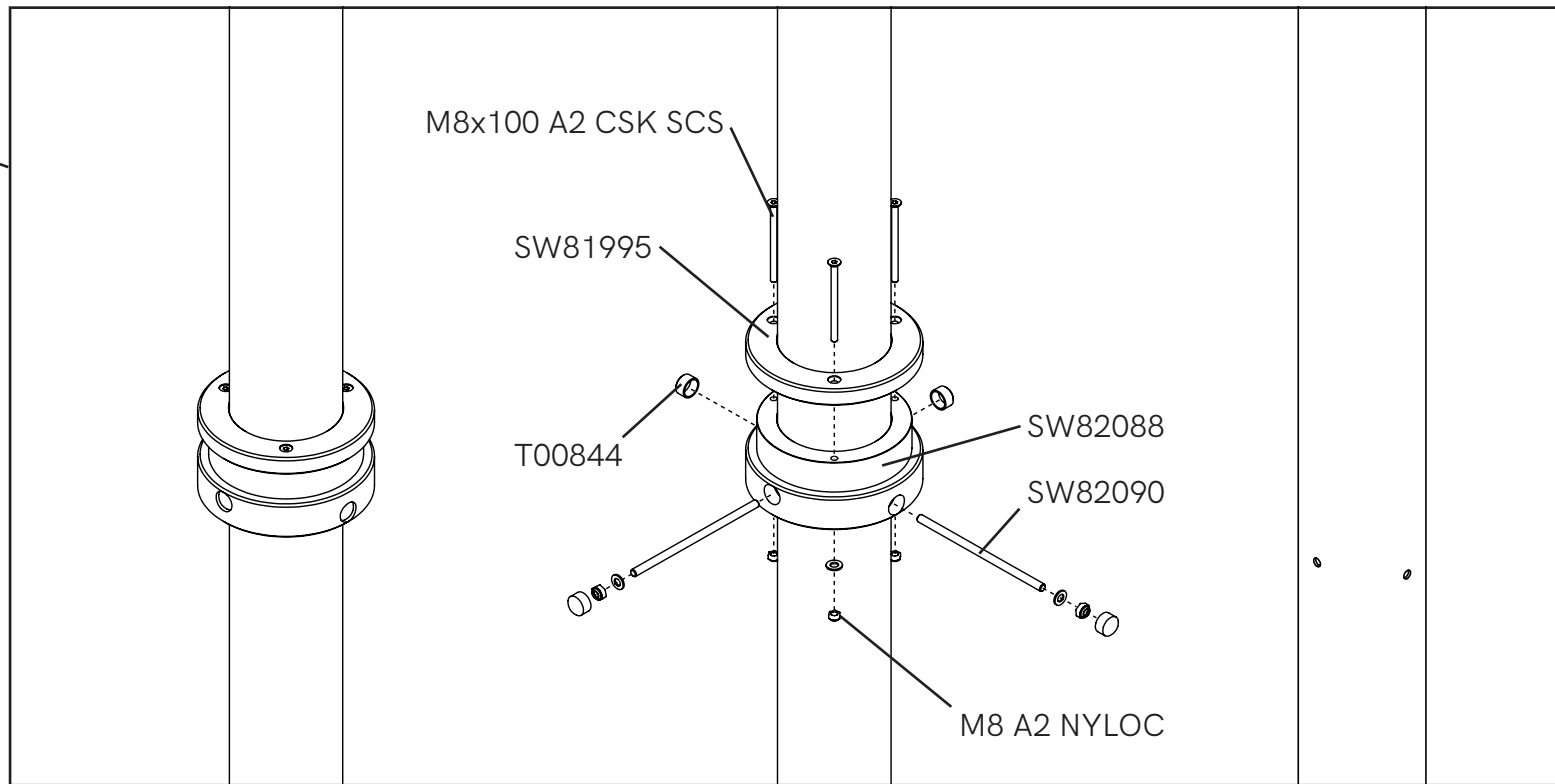
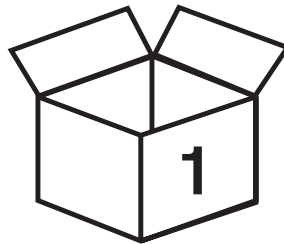
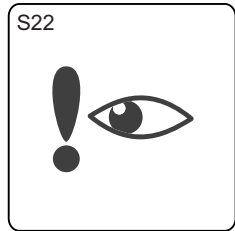
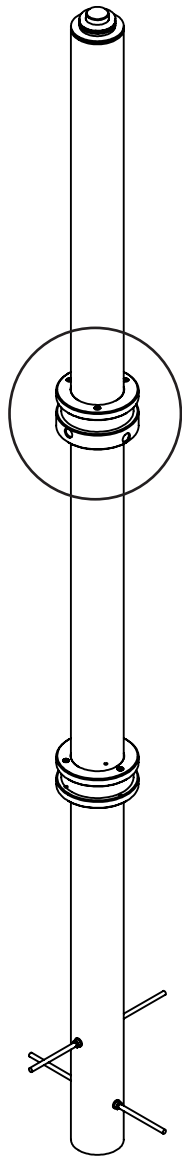

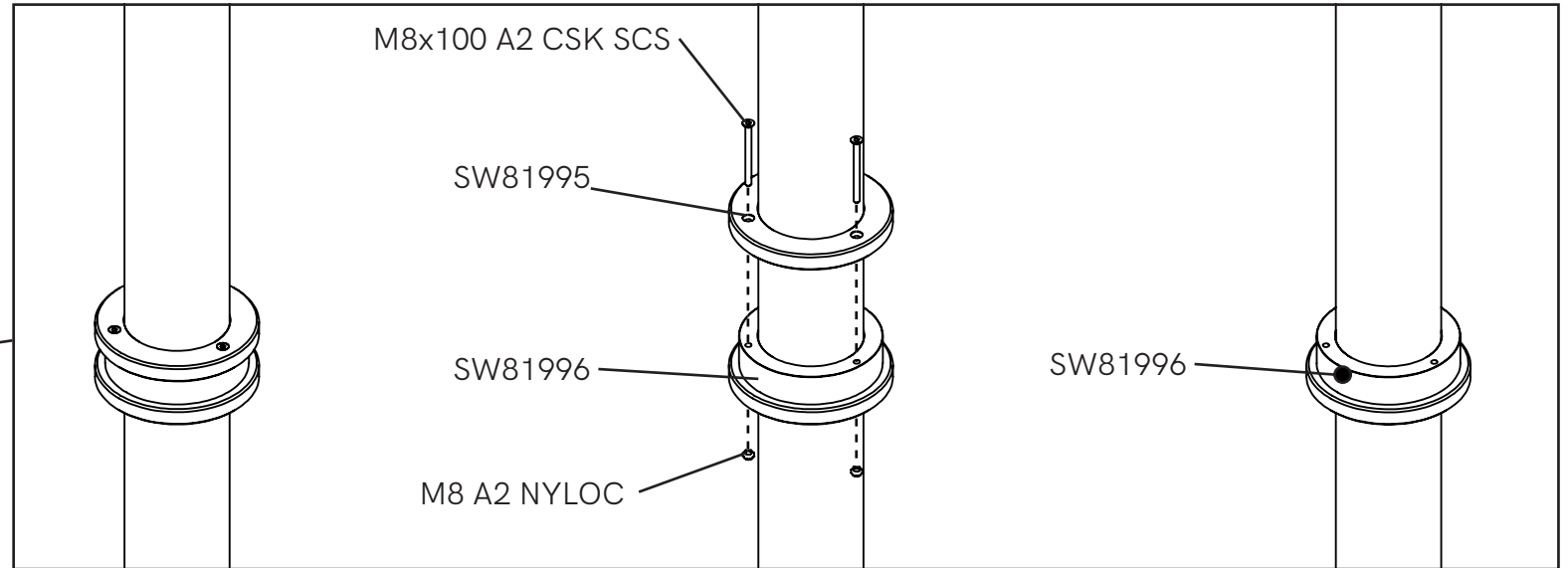
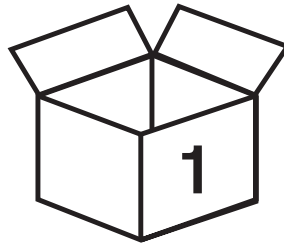
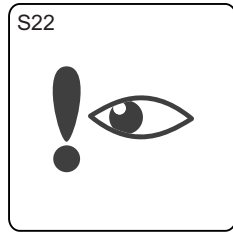
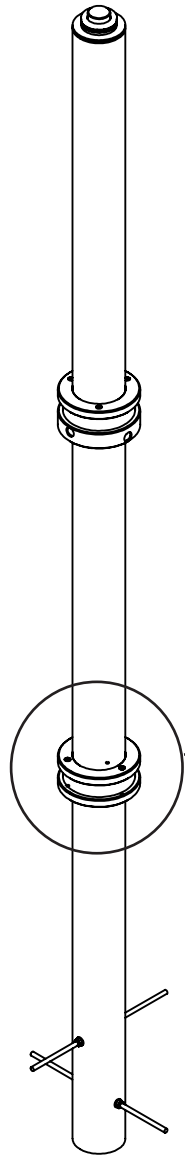

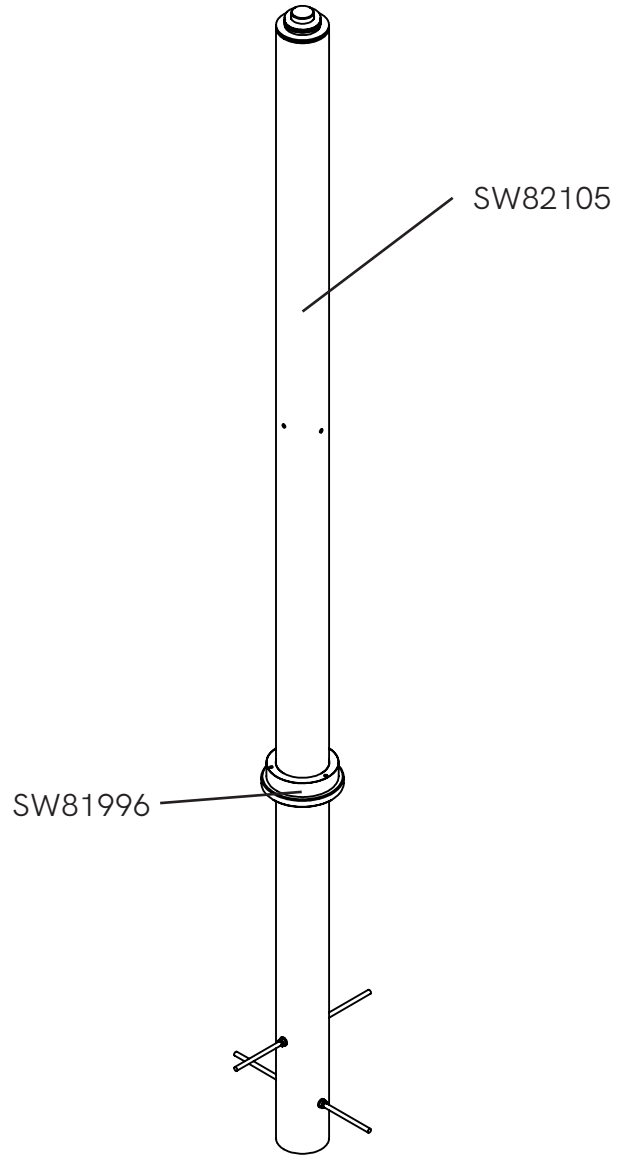
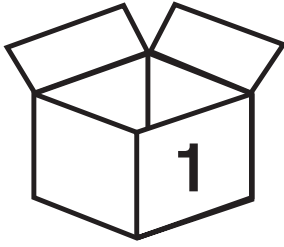
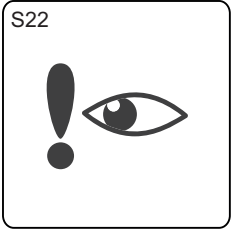

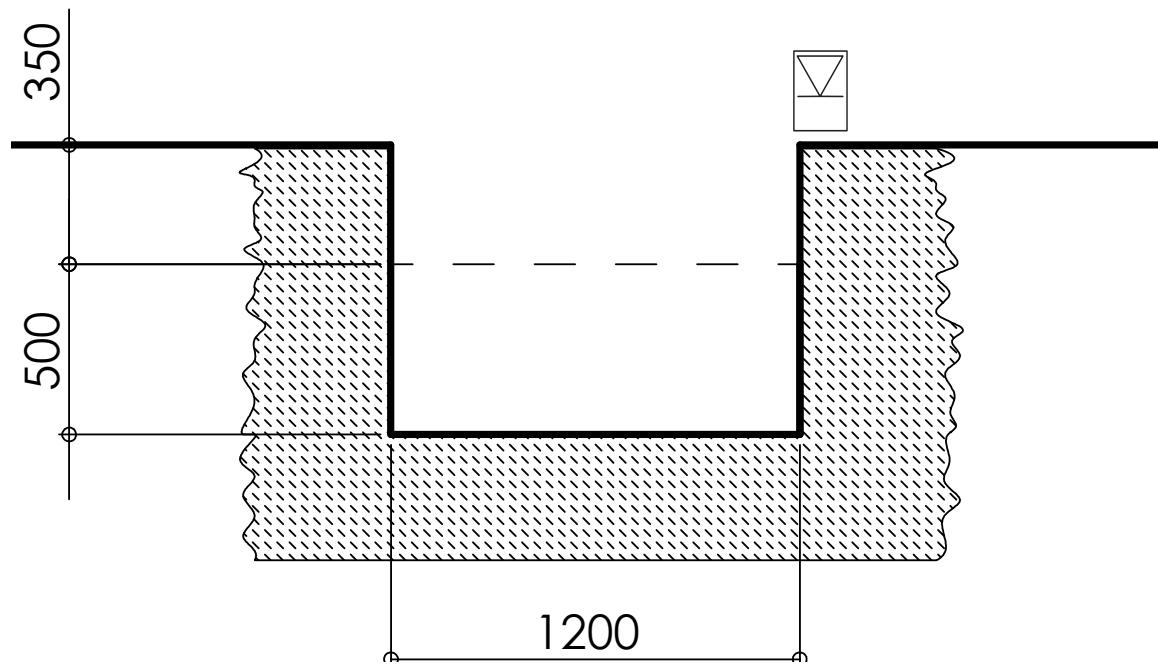
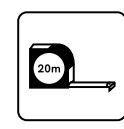
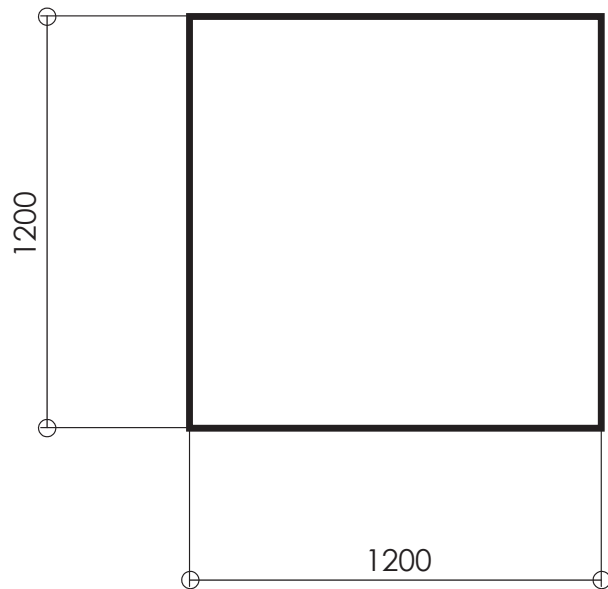

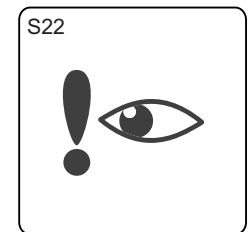
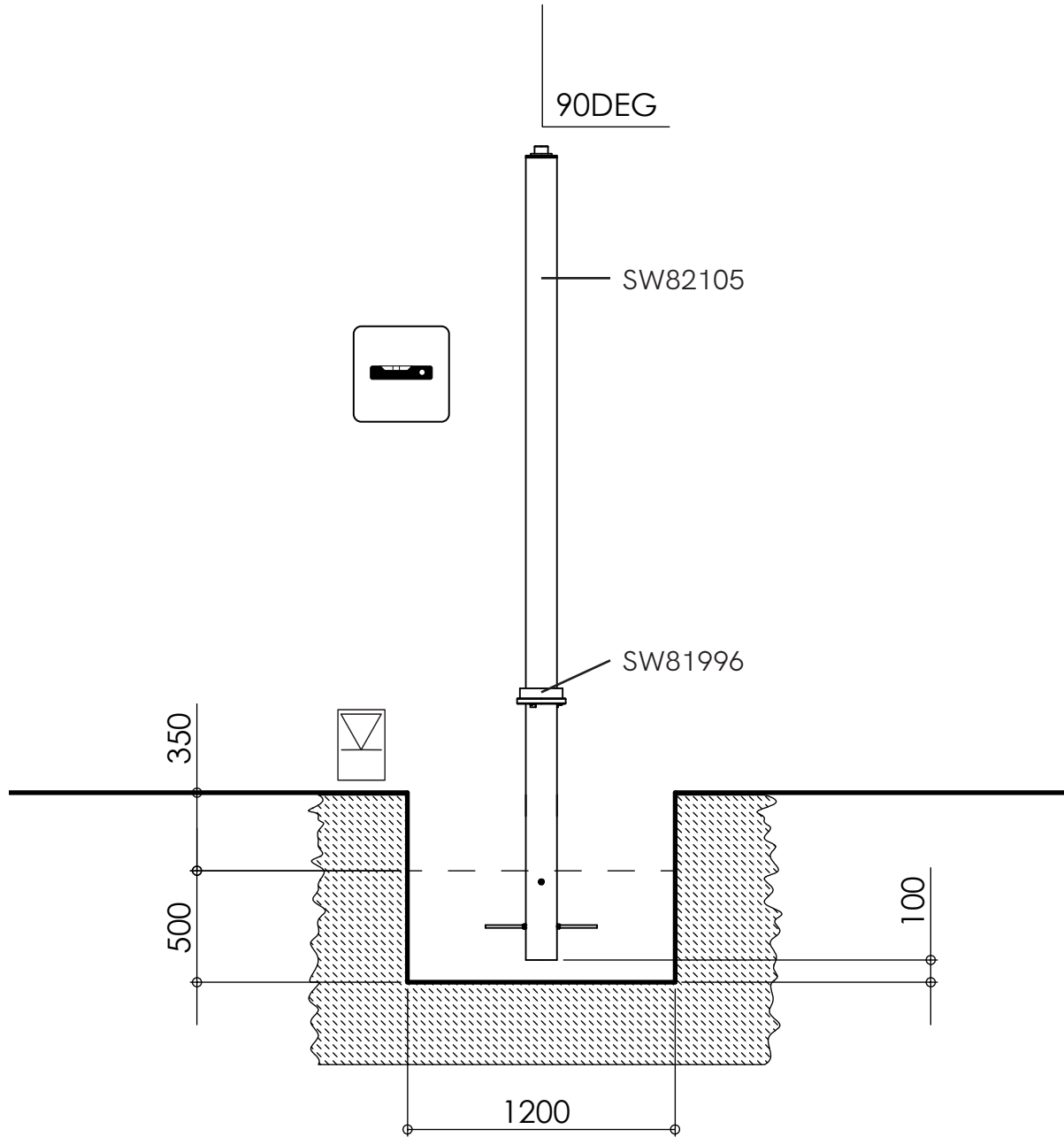
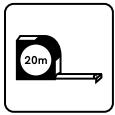



30N/mm²

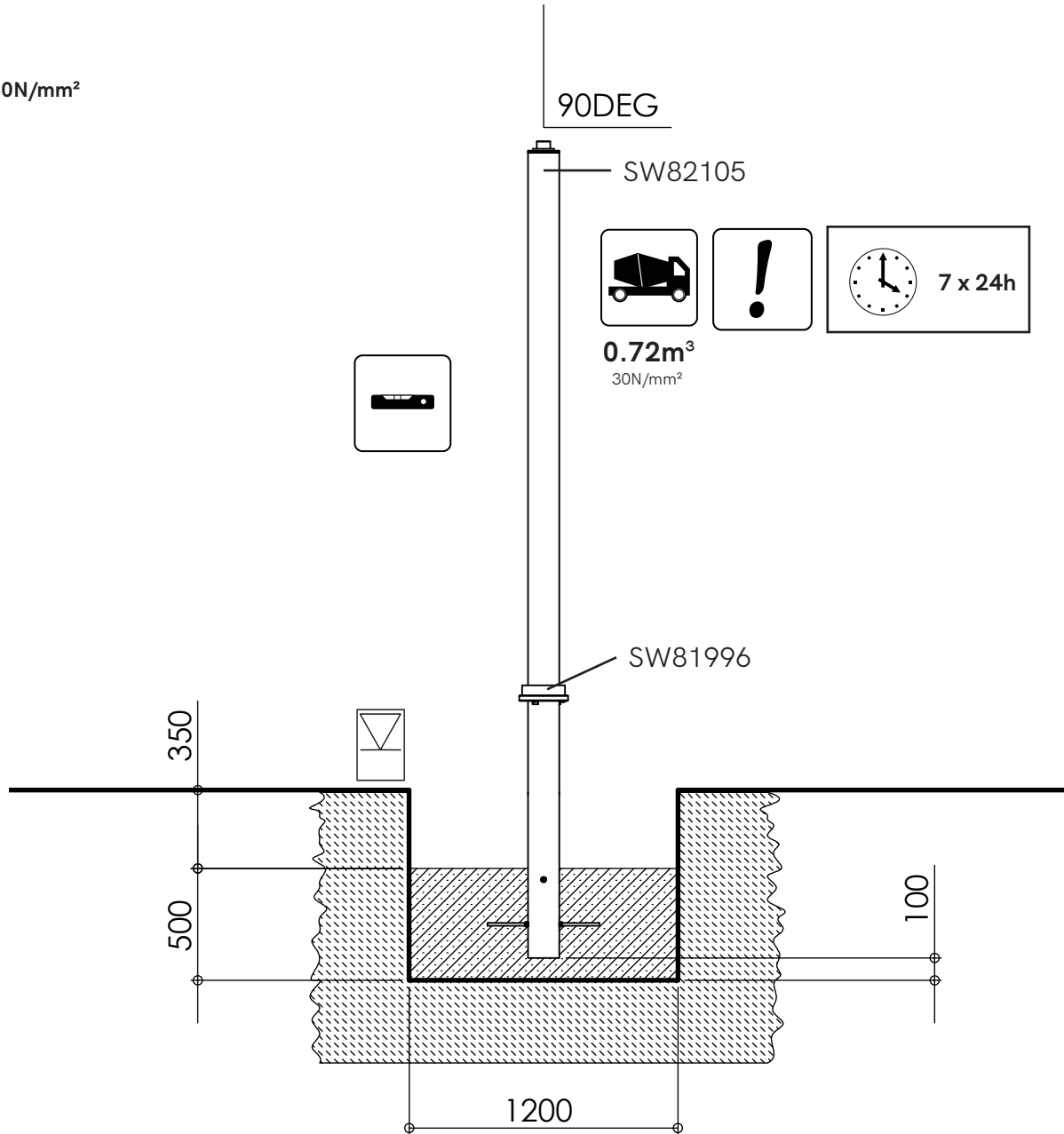
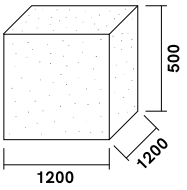

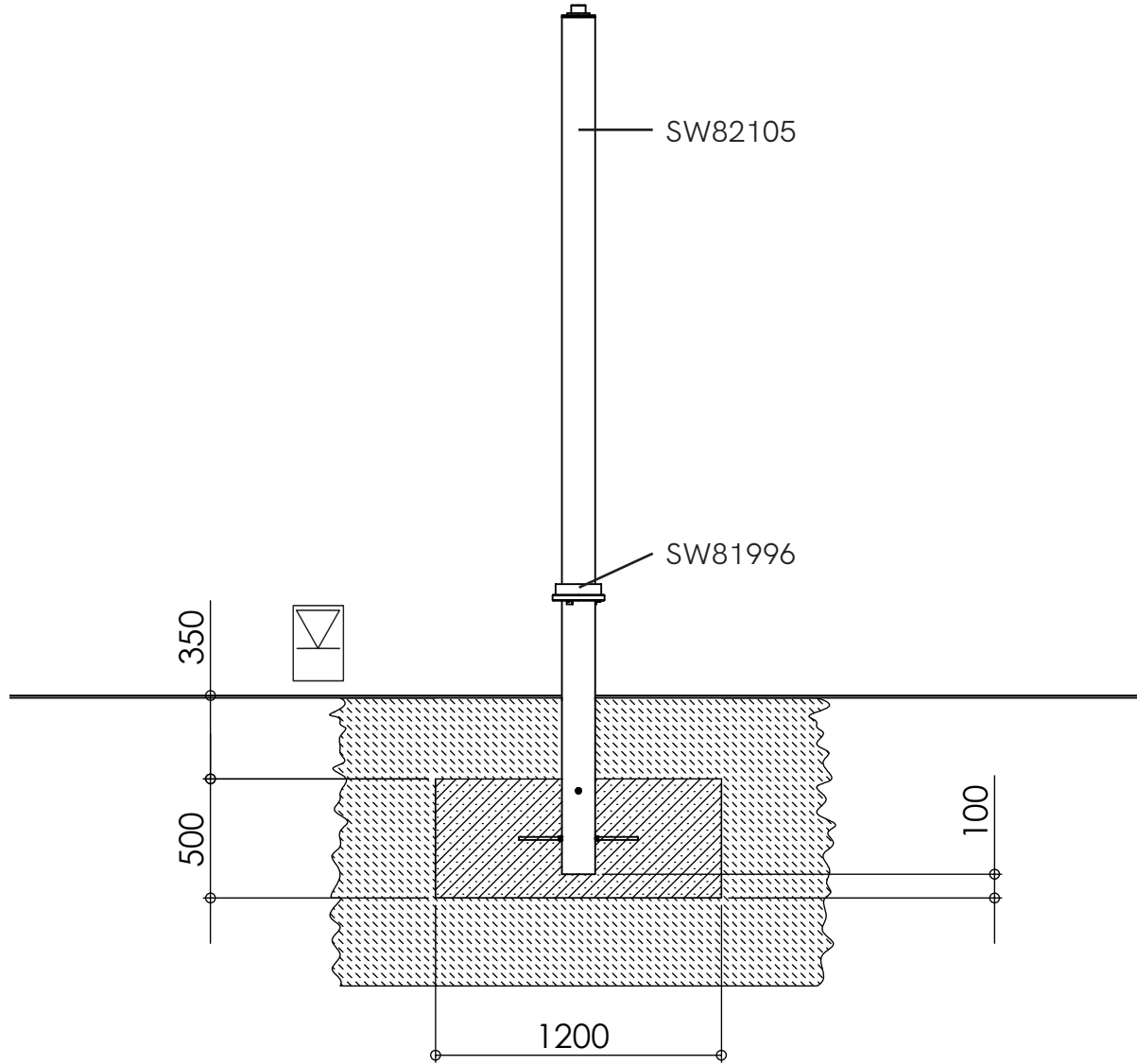

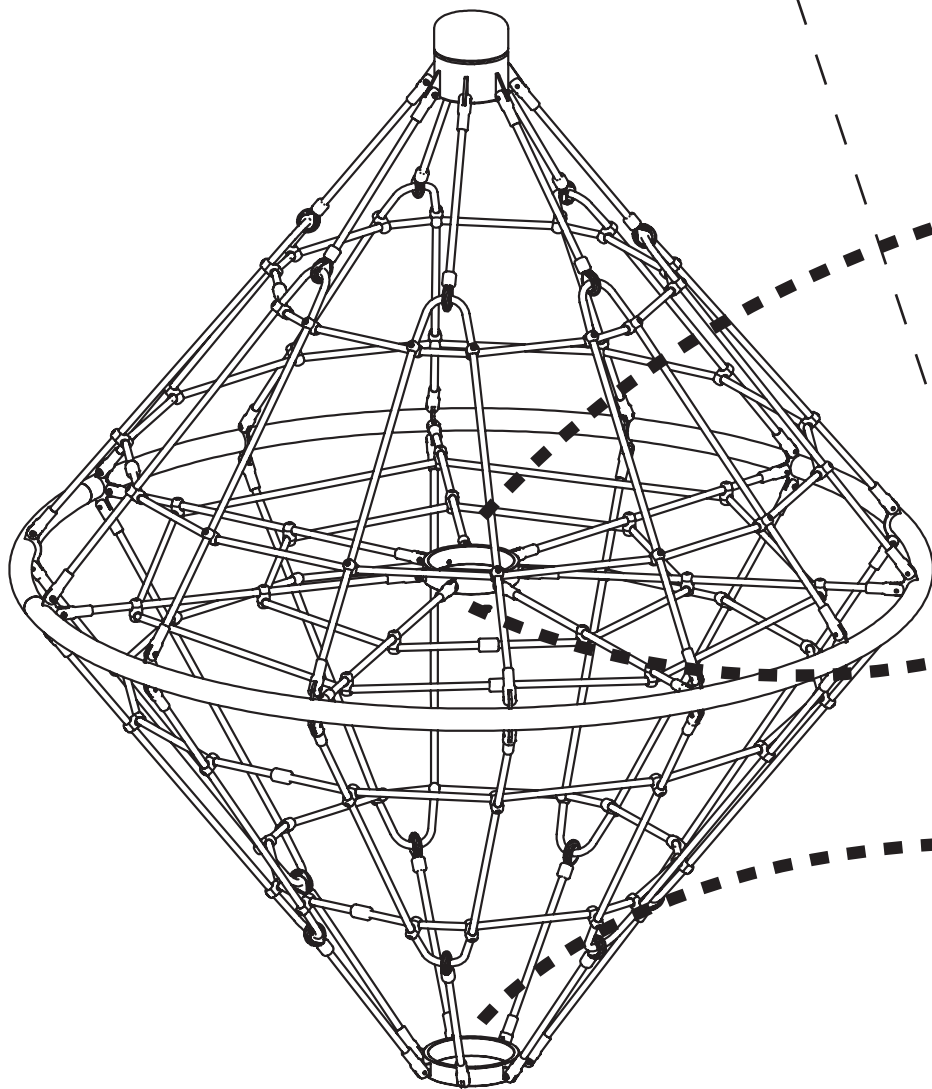
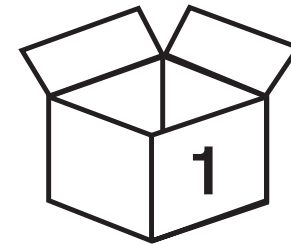
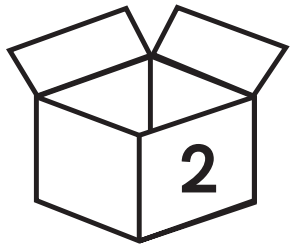

SW81995

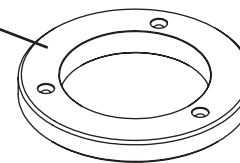

SW82088

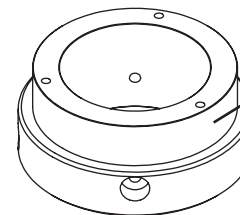

SW81995

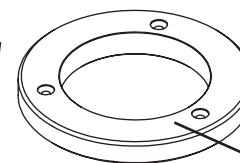

S12



kg
57

S34



2-3

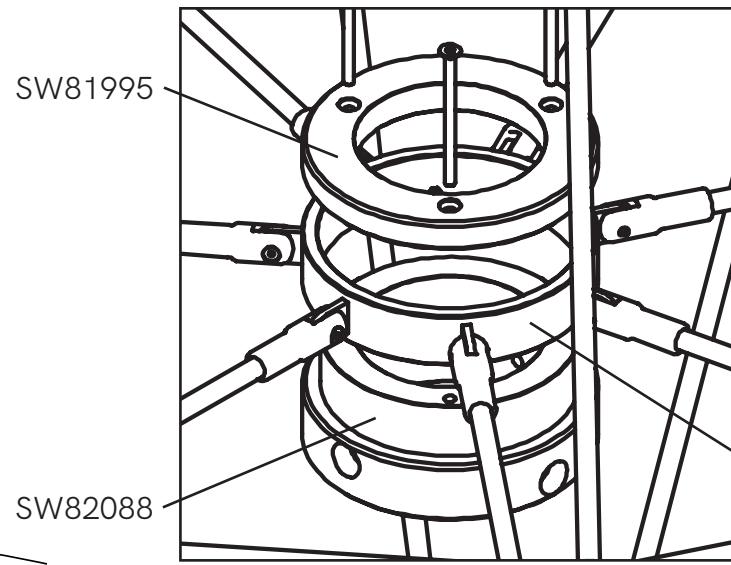
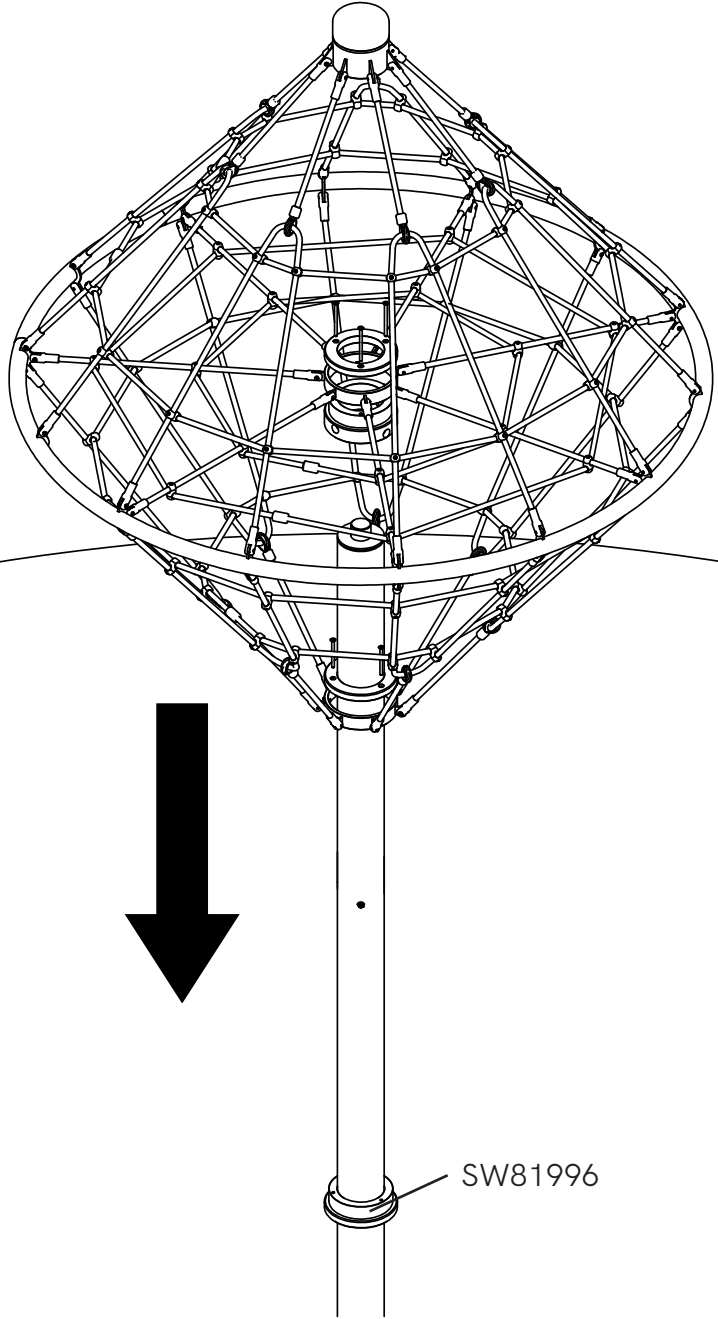

SW82026

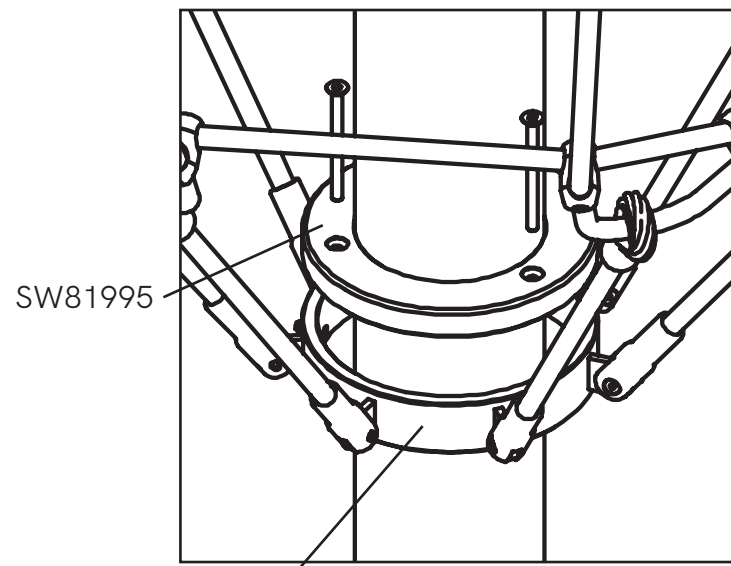

SW82026



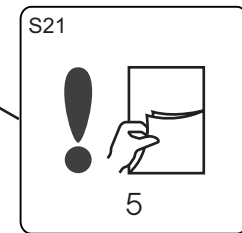
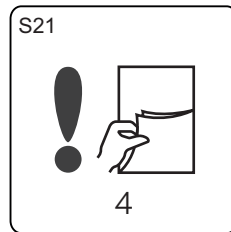
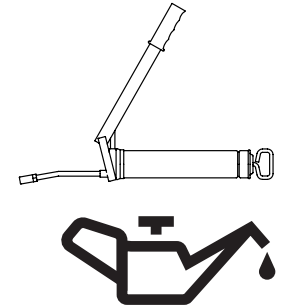
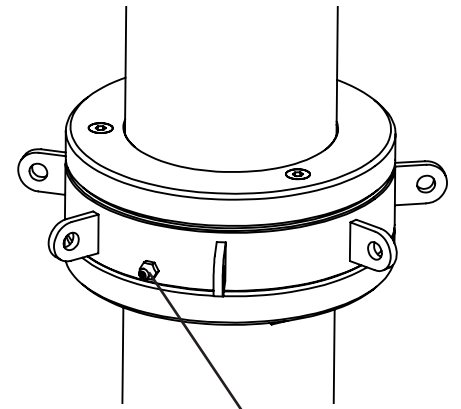
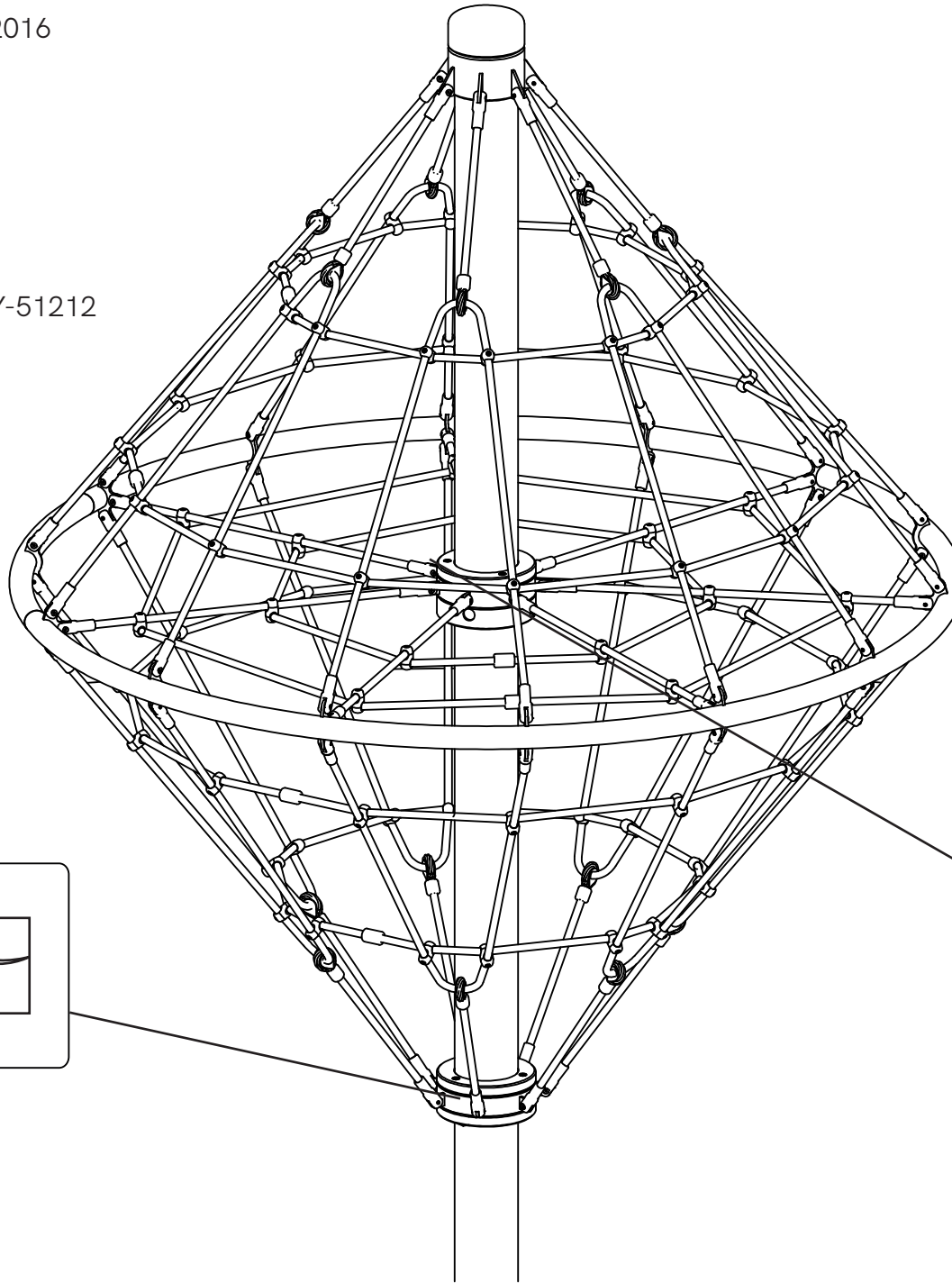
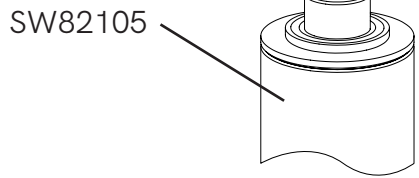
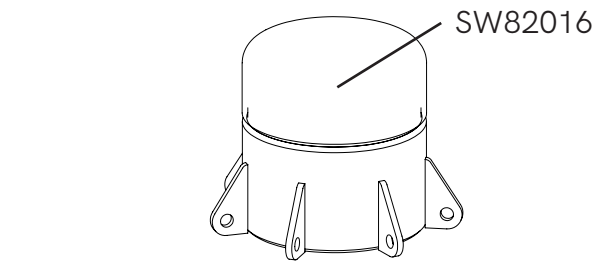

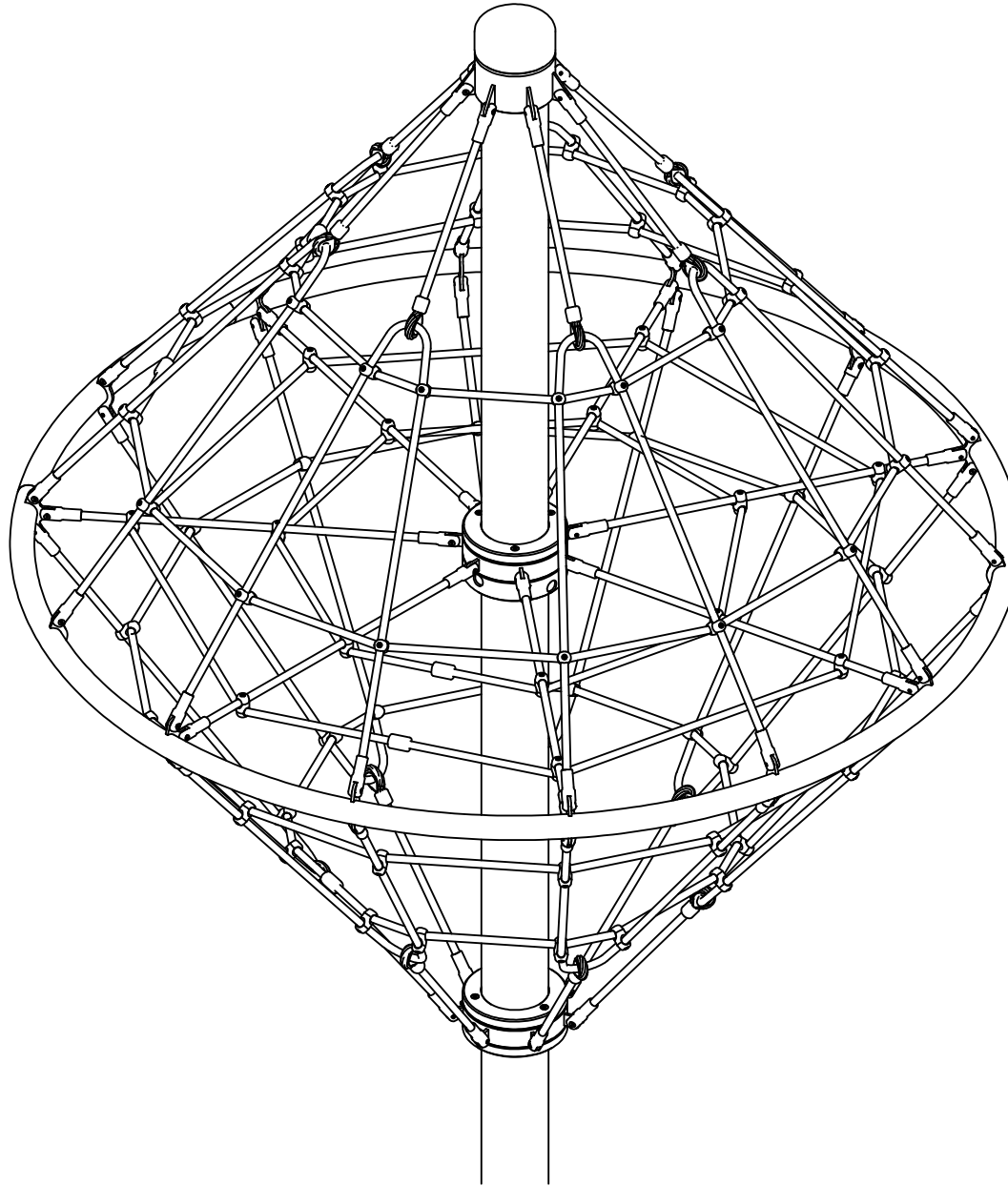



Tayplay Ltd

13A Riverview Business Park
Friarton Road
Perth
PH2 8DF
Scotland

Tel: +44 (0) 1738 449 084
Email: info@tayplay.com
Web: www.tayplay.com

